

Slotted Programming for Sensor Networks

Roland Flury
Roger Wattenhofer

Distributed Computing Group
ETH Zurich, Switzerland

Energy Efficient Communication

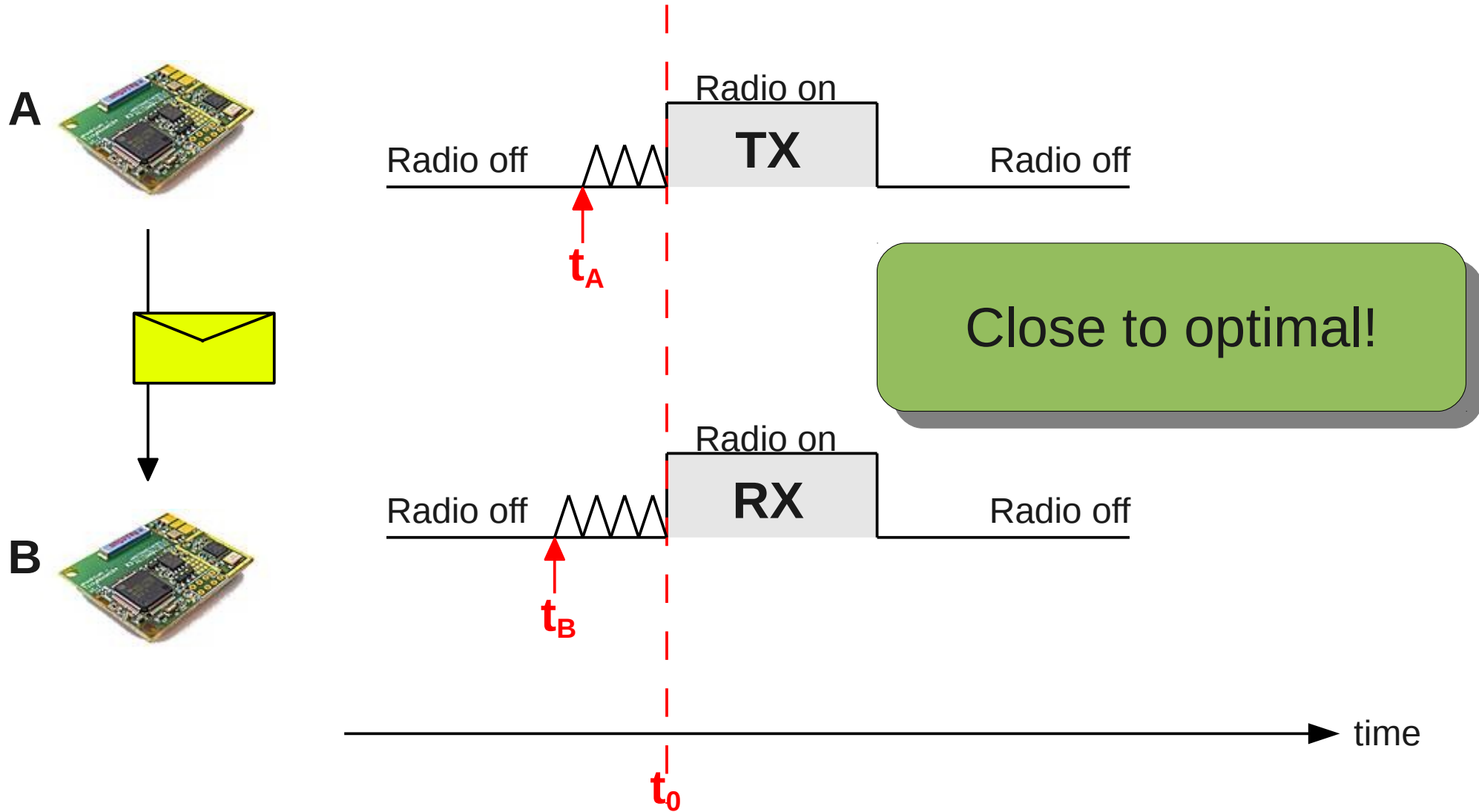

Requirements

- Good Synchronization
- Exact time execution
 - No delay
 - If B is too late, it misses the message
- Radio must be free to use
 - No other task may be using the radio

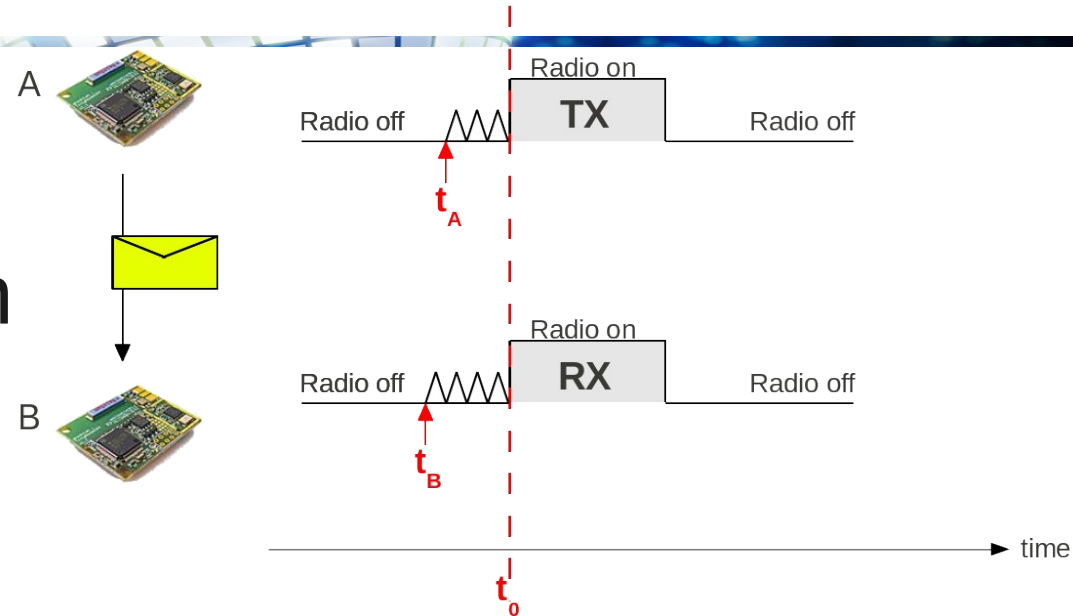

Slotted Programming can ensure these properties

Programming Sensor Nodes

- What are the time critical sections?
 - E.g. wake up the radio at t_0 to receive a message
- Can they be delayed by another task?
- Can we avoid it?
- Check access to any device, not only radio

Need to analyze the entire application
Any part may interact with any other part

Traditional vs Slotted

Traditional Application

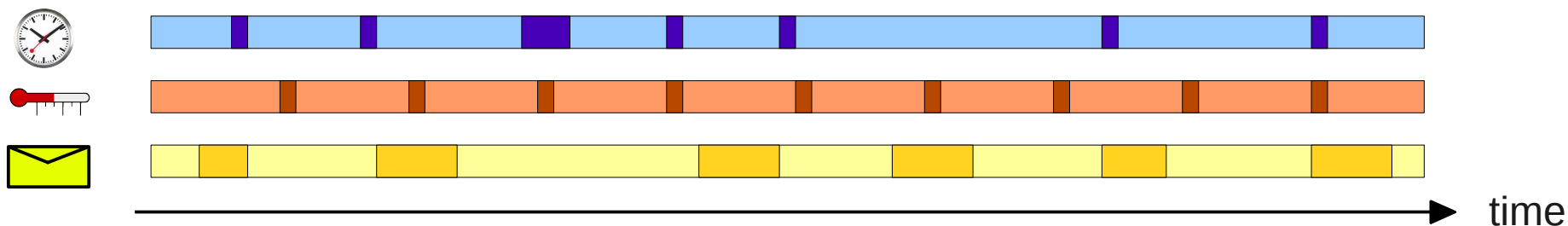

Slotted Application: Temporal separation of the tasks

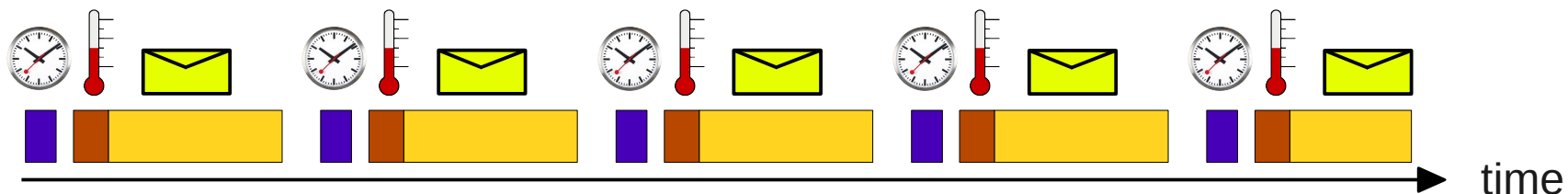

- No interference of other tasks
- Can analyze each task separately

Slotted & Synchronized

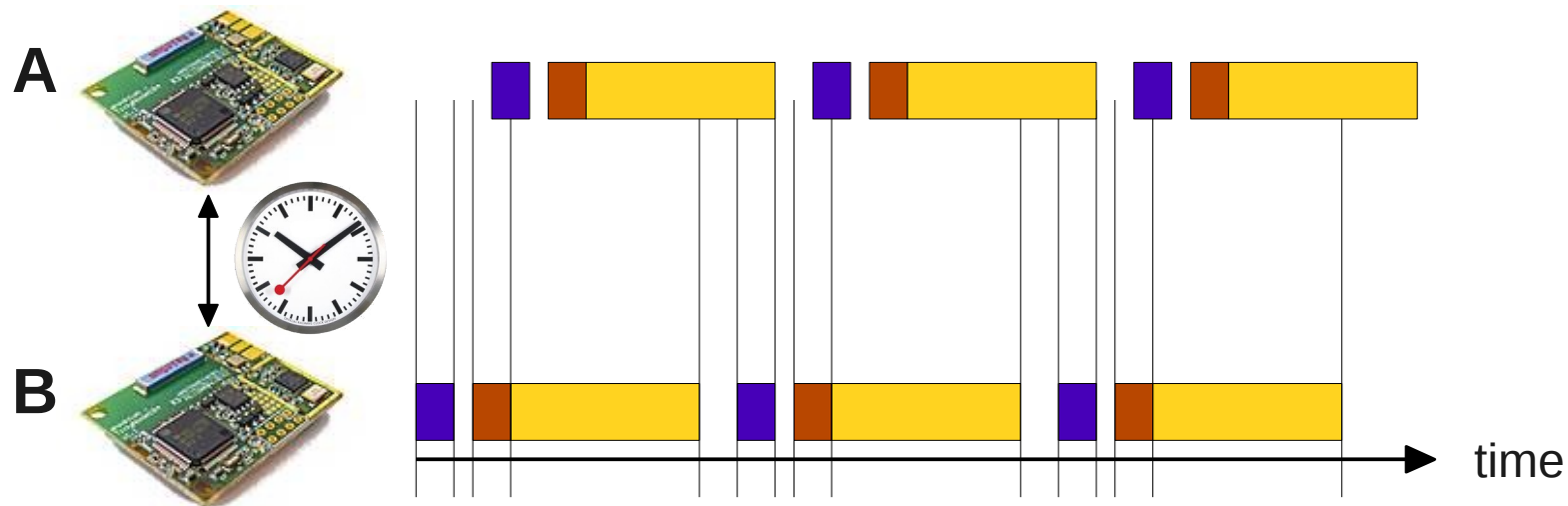

All nodes need to be synchronized

- Clock sync module does all the work
- Transparent to the other modules

Slotted Programming

Easy case: repetitive schedule

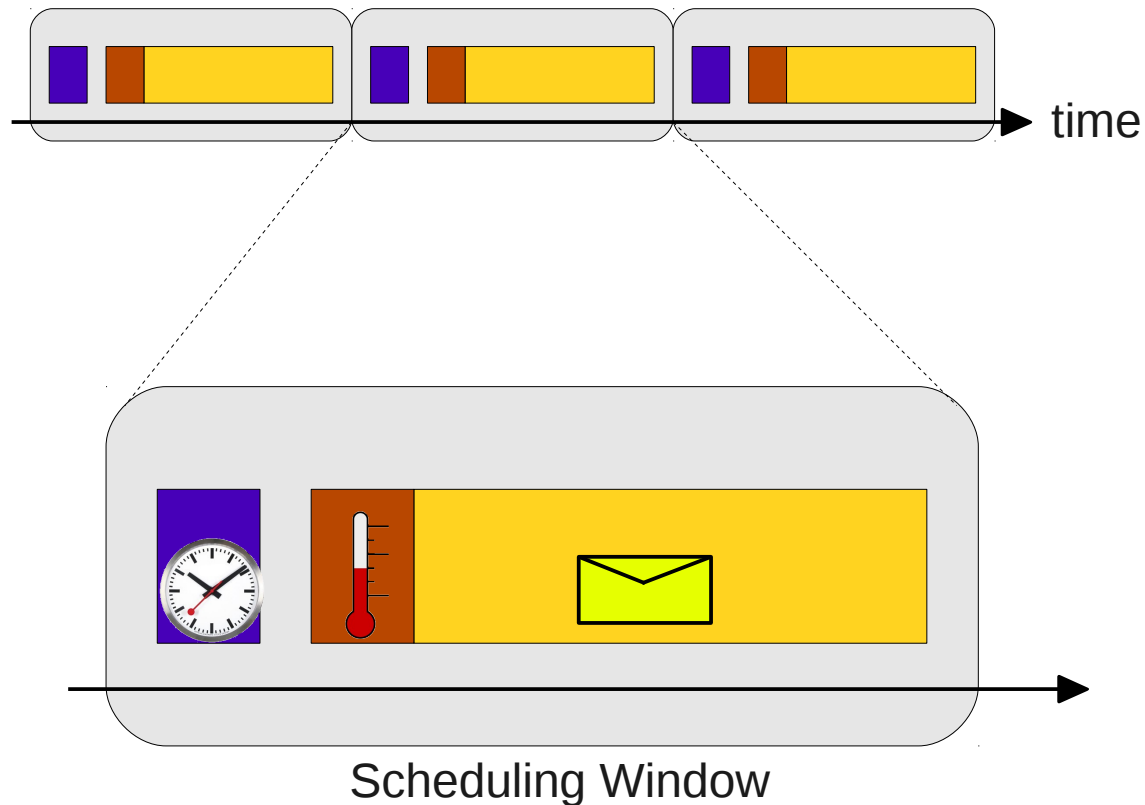

Advanced schedules are possible

Slotted *Programming*

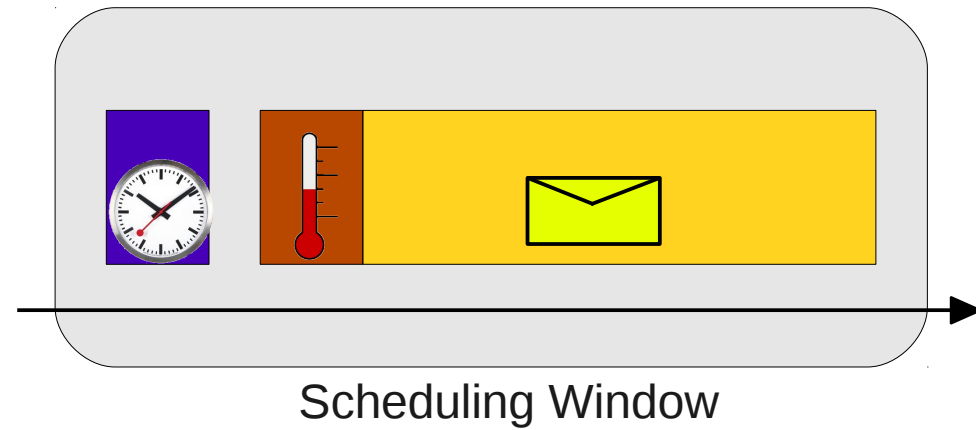

Slotted Programming

- 1) @boot: allocate slots
- 2) schedule slots:
startSlot() - stopSlot()

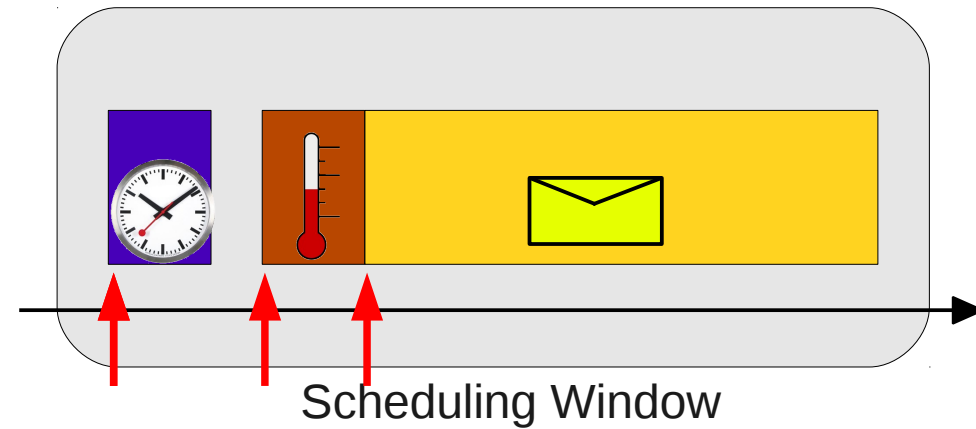

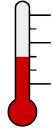
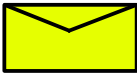
	@boot	@runtime
 Clock Sync	init()	startSlot() stopSlot()
 Sampling	init()	startSlot() stopSlot()
 Routing	init()	startSlot() stopSlot()

Slotted Programming

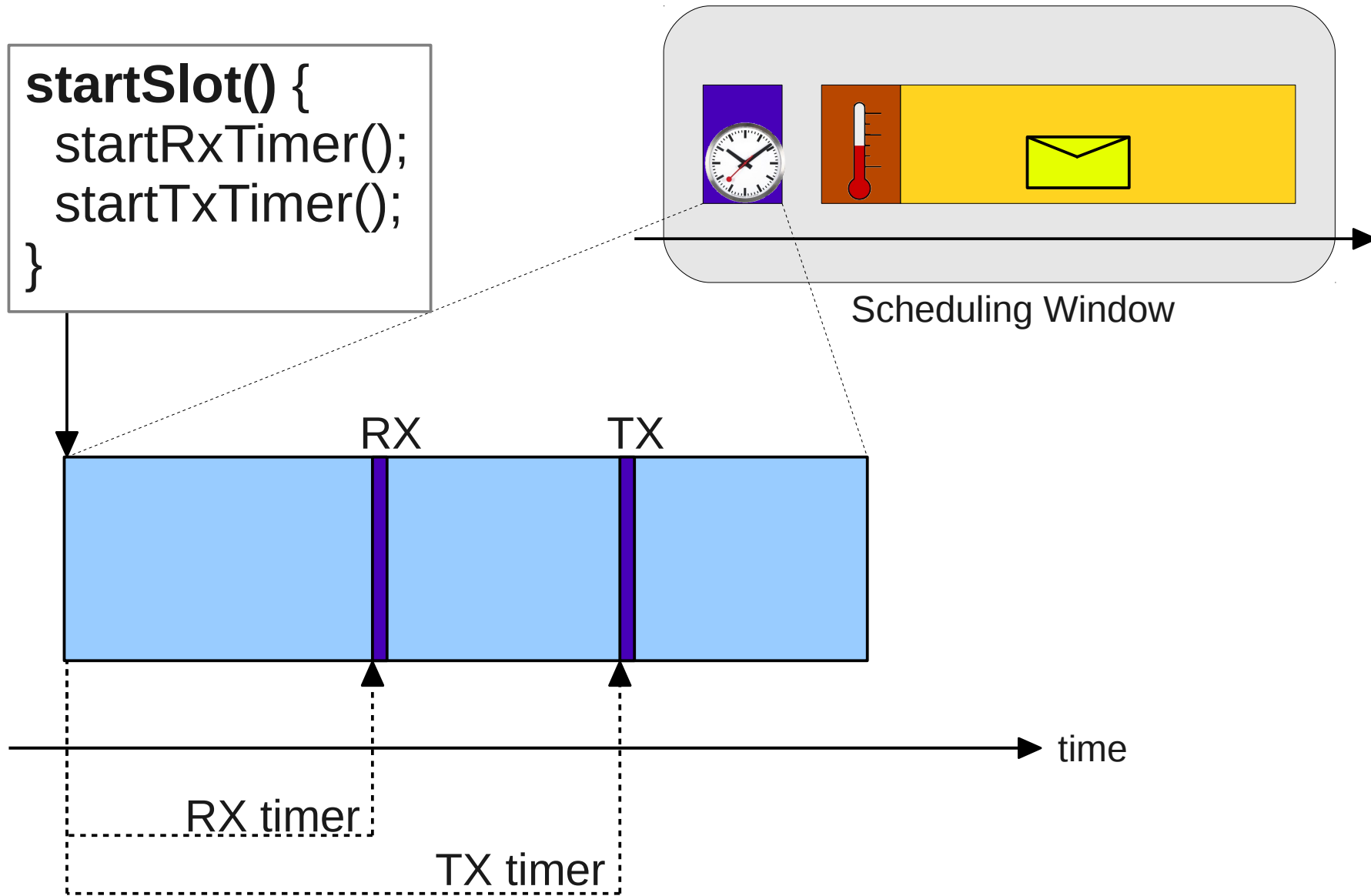

Slotted Programming

Very simple: Time division

Too simplistic?

- No side effects
 - Additional module does not disturb existing app
- Guaranteed access to resources
- Simplified software structure
 - Step *towards* provably correct software
- Energy efficient applications
- Clock Sync is transparent

Examples

- **Slotted Clock Synchronization**
- Energy Efficient Alarming
- Data gathering

Goal

Synchronize all nodes of a network

A master node dictates its time
to the remaining nodes

Slotted Clock Synchronization



Bootstrap procedure to get rough synchronization

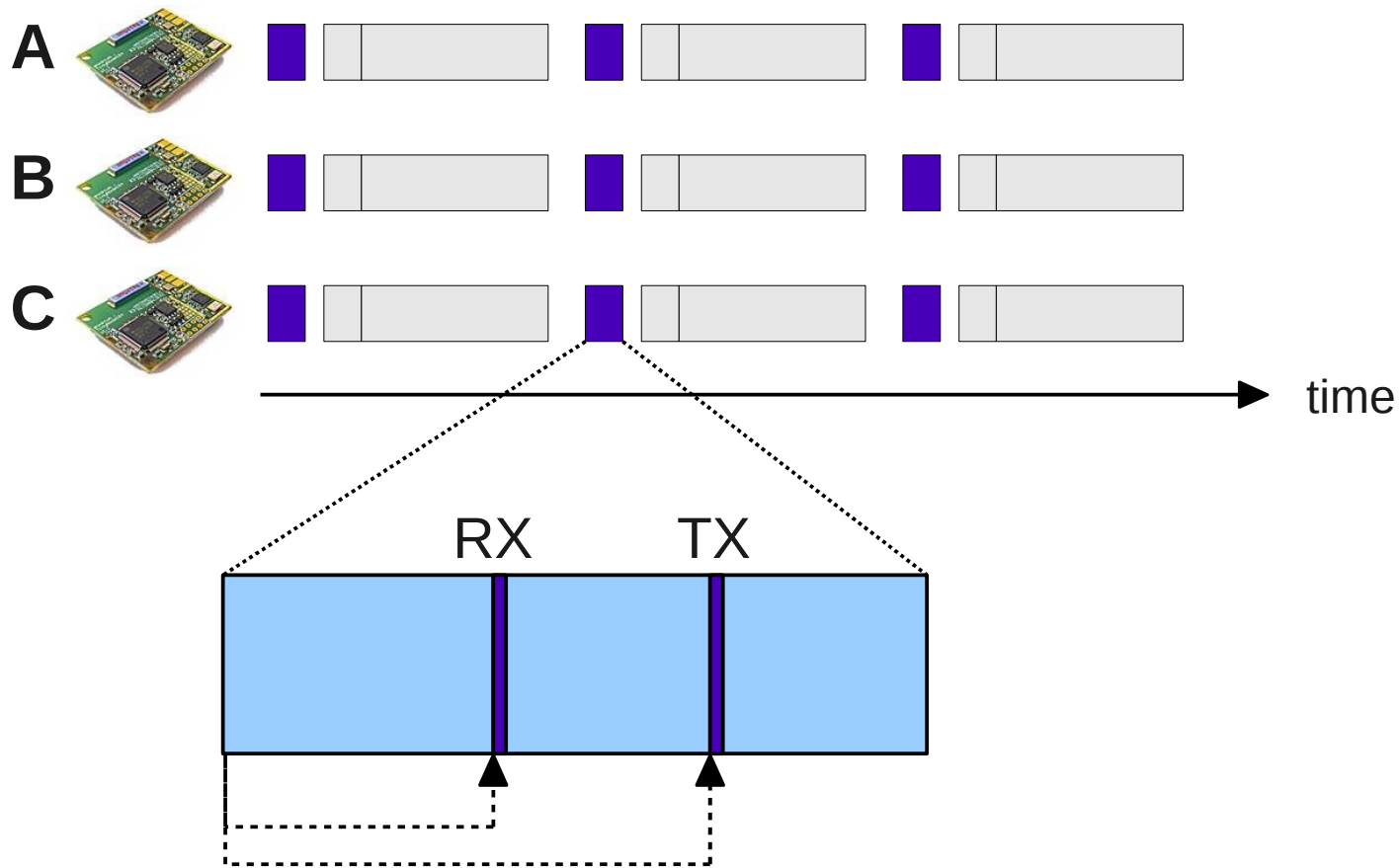

Pipelining

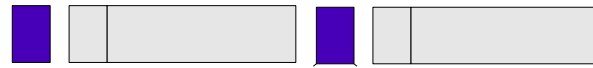

time →

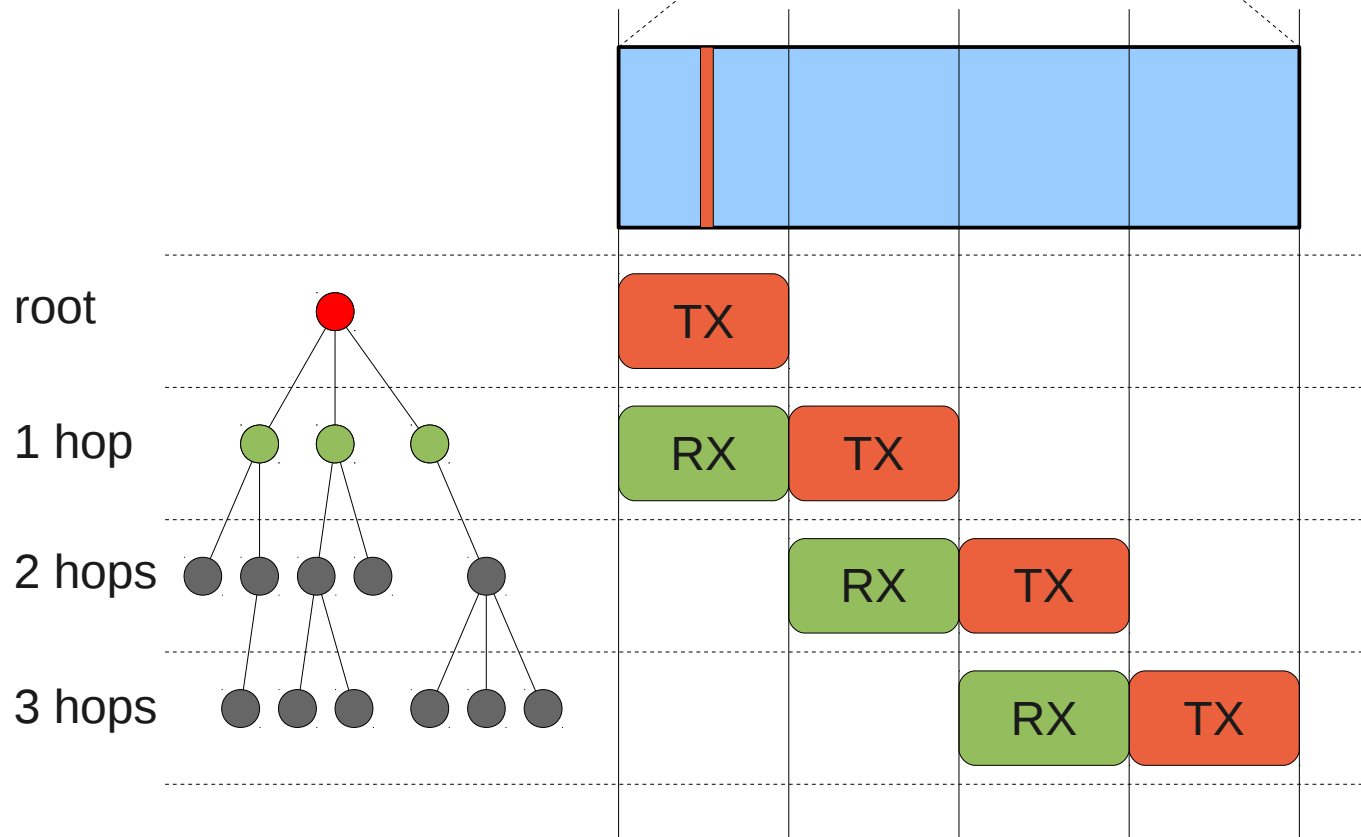

Pipelining

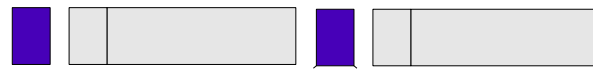

time →

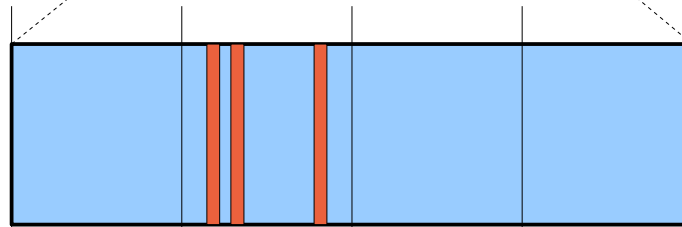

root

1 hop

2 hops

3 hops

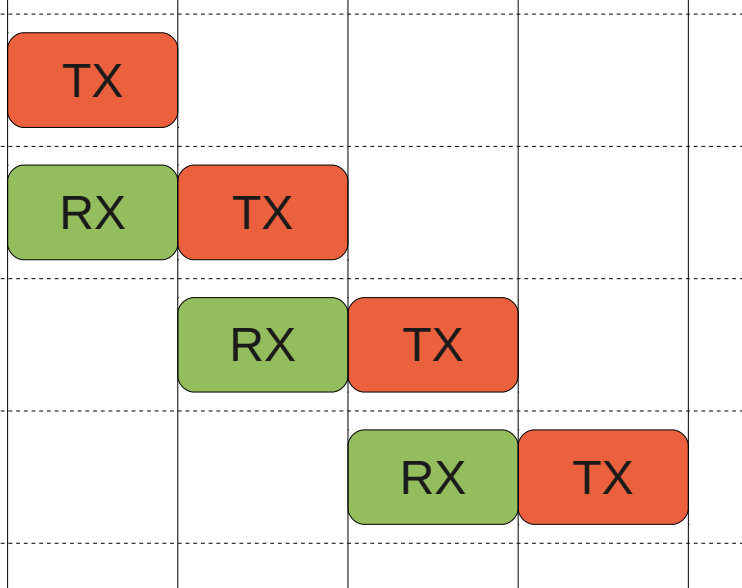
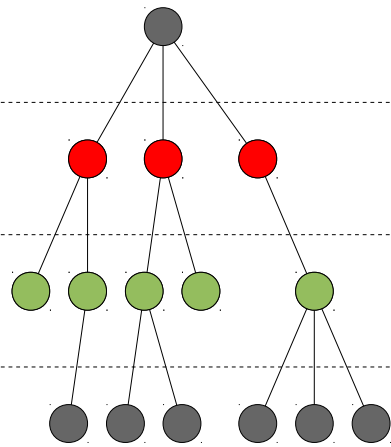

Pipelining

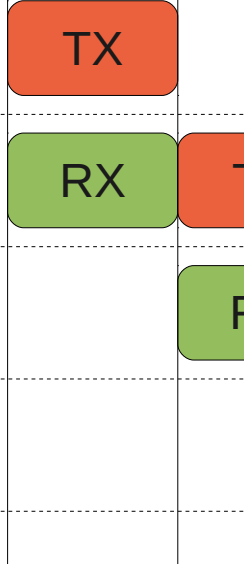
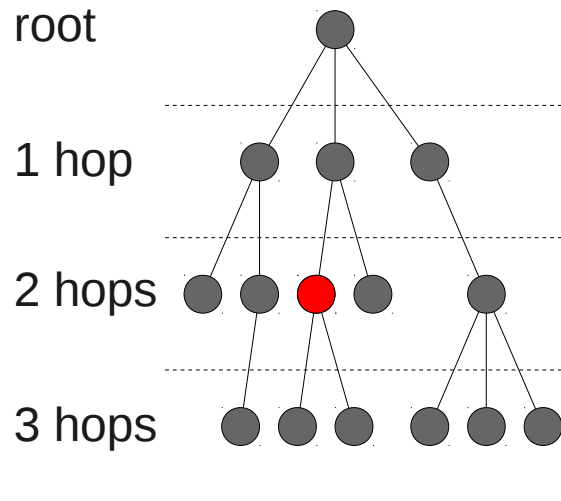
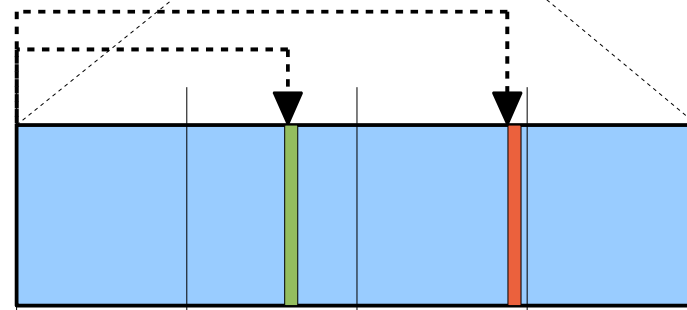
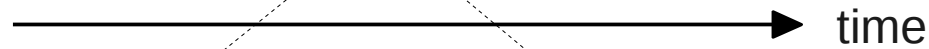
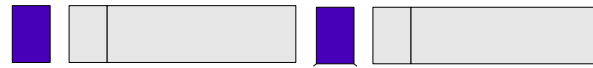

**Best synchronization
we can have!**

Lenzen, Sommer, Wattenhofer
@Sensys 2009

Slotted Clock Sync



- Timers not delayed
- Access to radio not blocked
- Transparent to remaining modules:
 - All timers are relative to the time when the current slot started

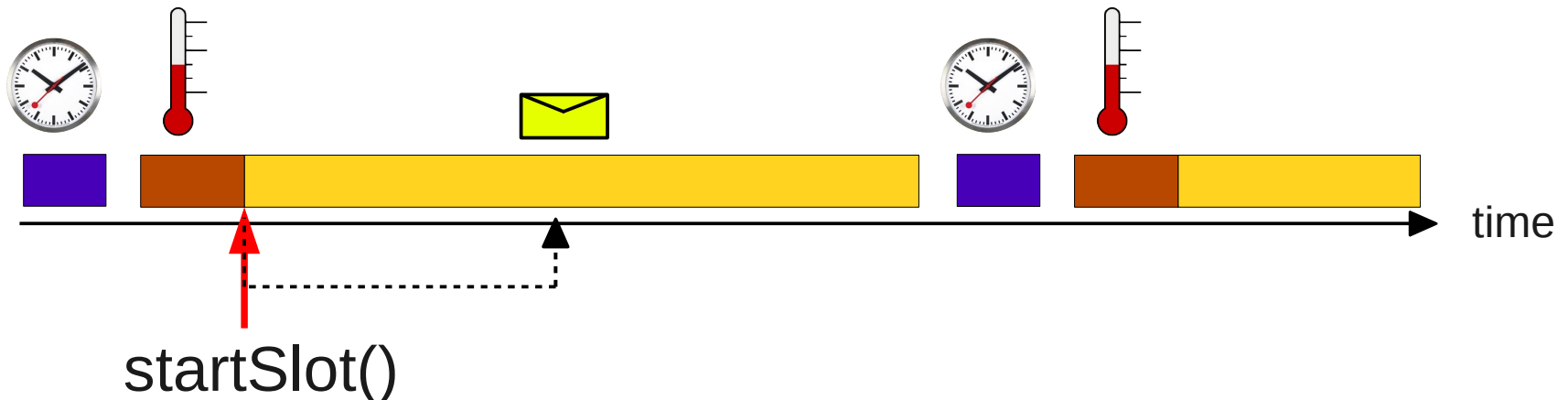
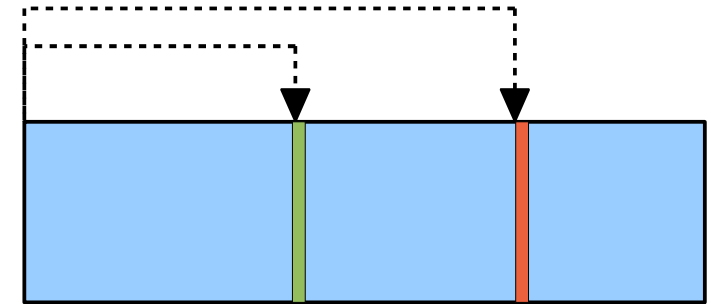

Examples

- Slotted Clock Synchronization
- **Energy Efficient Alarming**
- Data gathering

Goal

- a) Inform the root node about an event
- b) Inform all nodes about an event

energy efficient and reliable

Energy Efficient Alarming



Initial idea: Pipelined RSSI sniffs

- Send a message to transmit an alarm
- Measure the RSSI value to detect an alarm
- Several nodes may indicate an alarm in parallel

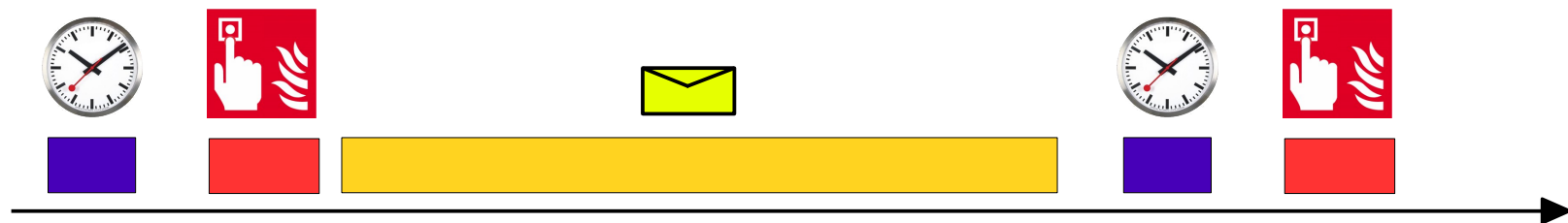

Alarm!

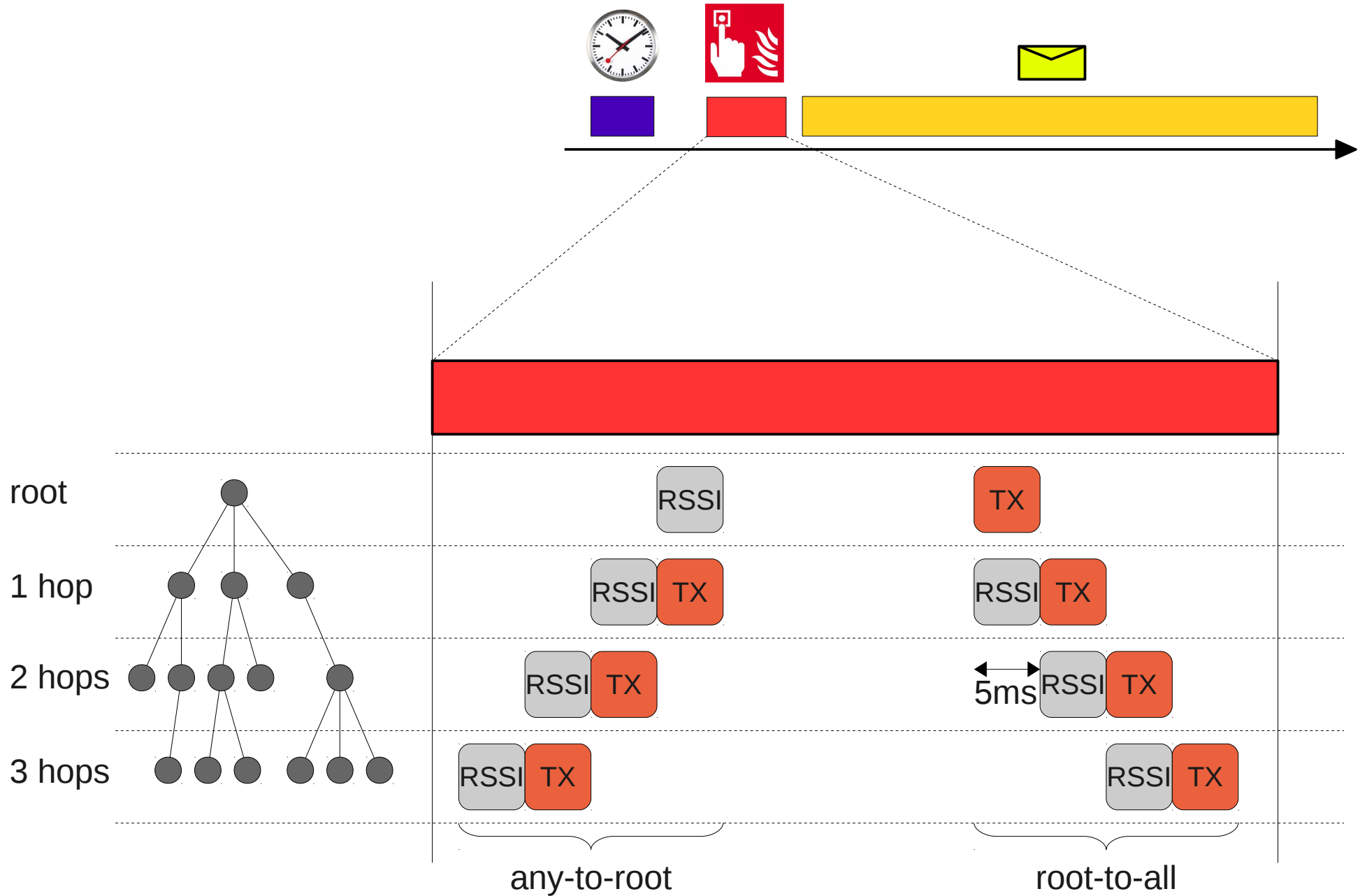

False Alarm!



- RSSI works fine – indoors
 - Around 30% false alarms when deployed outdoors
- TinyNode with Semtech XE1205 Radio
 - FSK modulation: $\left\{ \begin{array}{l} 0 \text{ } \text{~~~~~} \text{ } f_0 \\ 1 \text{ } \text{~~~~~} \text{ } f_1 \end{array} \right.$
 - Announce an alarm: Send at f_0
 - No alarm: be quiet
 - Detection:
 - No alarm: white noise (50% '1' and 50% '0')
 - Alarm: > 75% '0'
 - Several nodes may indicate an alarm in parallel

Signaling



- Reuse same pipeline as for RSSI:

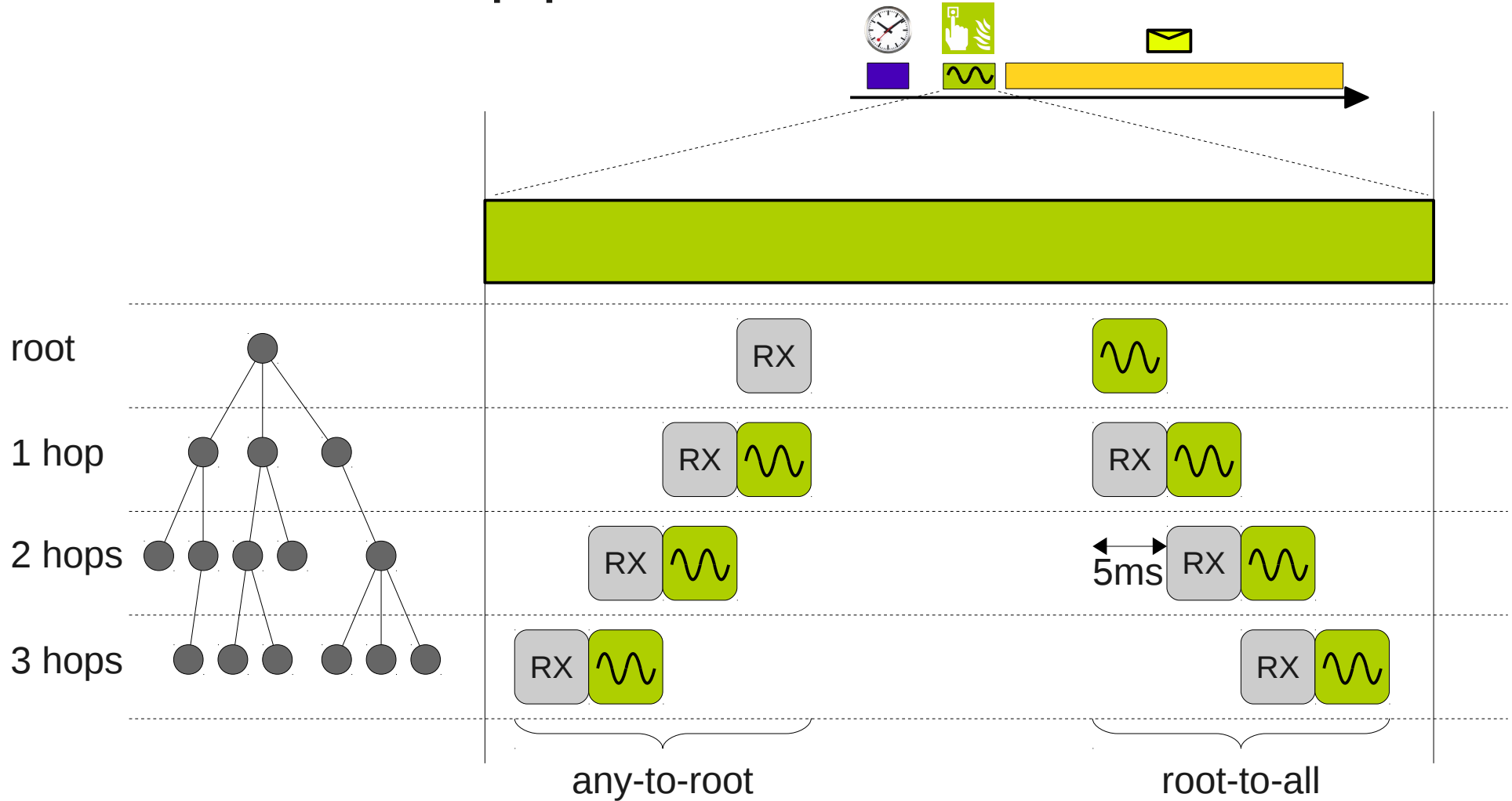

Slotted Programming

- How to compare the RSSI and Signaling?

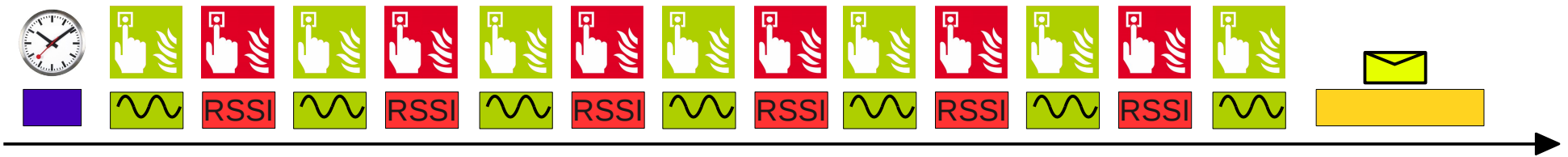

- Slotted Programming = Modularity
 - Easy reuse of software modules
- Energy Efficient: Tight pipelining
 - No delays for wakeup, guaranteed access to radio
- False Alarms: 30% RSSI vs 1% Signaling

Examples

- Slotted Clock Synchronization
- Energy Efficient Alarming
- **Data gathering**

Goal

Collect sensor readings at a base station

Slotted Data Gathering

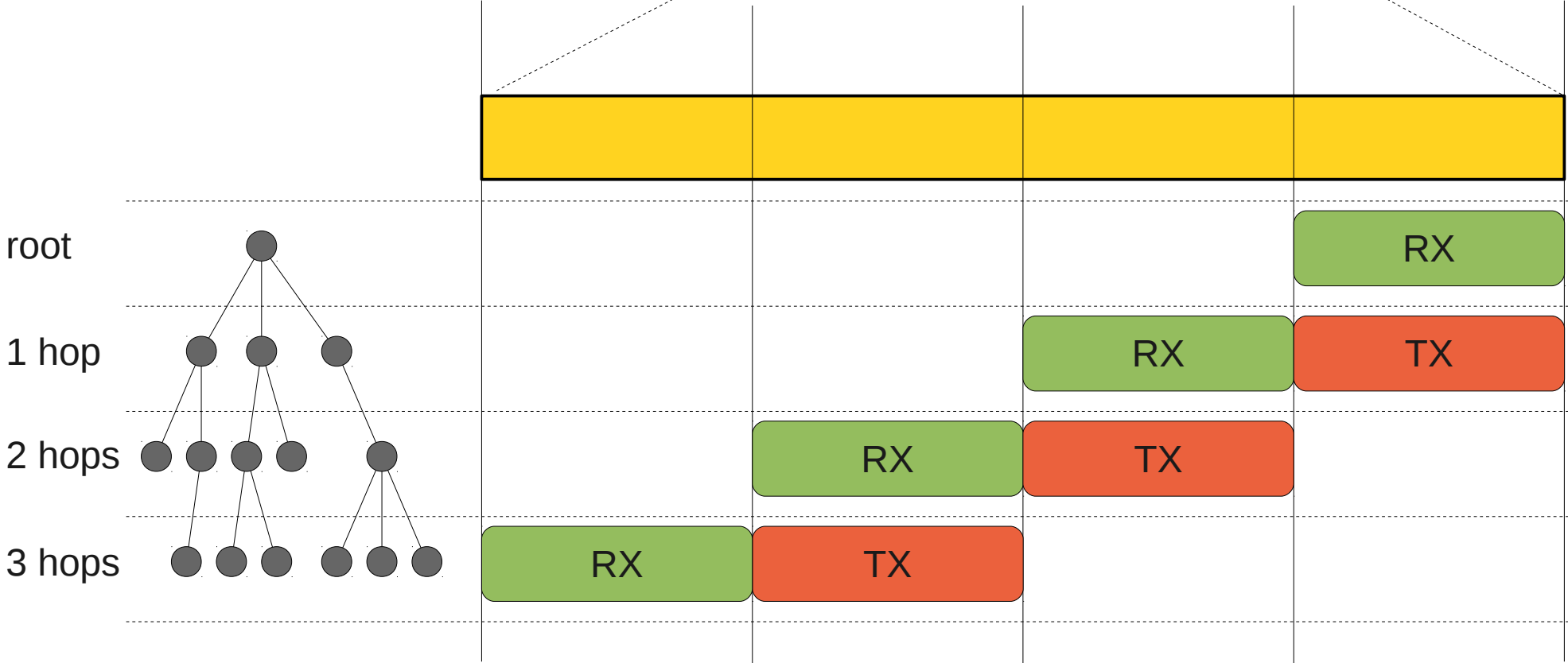
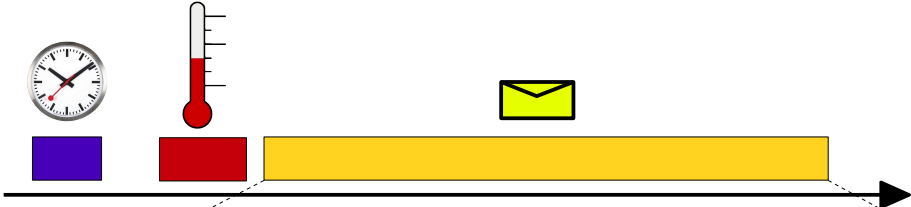

Slotted Data Gathering

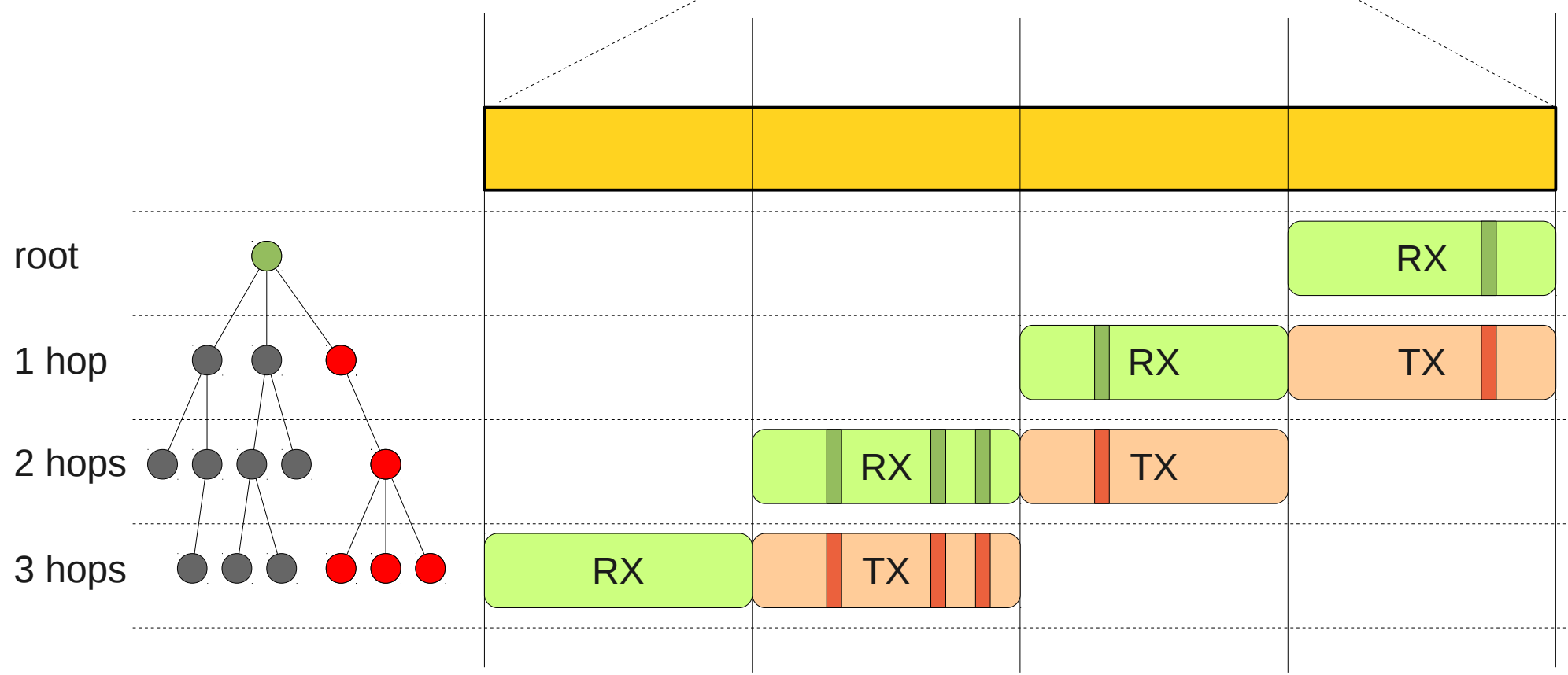
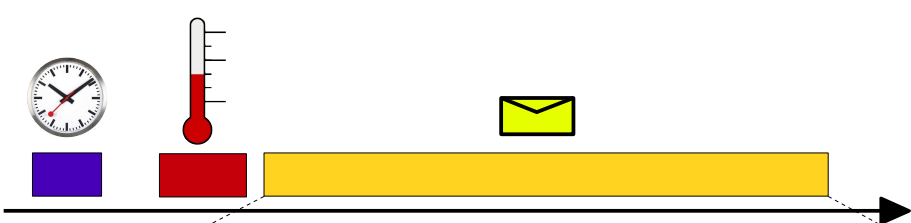

Slotted Programming - Recap

- Simple time division
- Modularity
- No delays, guaranteed access to resources
- Energy efficient applications
 - Tight scheduling & wakeup patterns
- Transparent Clock Sync
- Simplified software structure
 - Each module can be analyzed independently

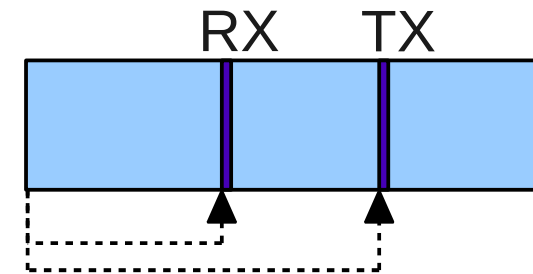
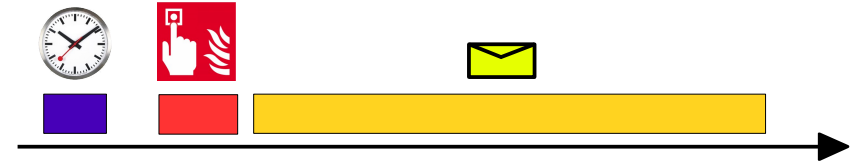

Thank You!

slots – an extension to TinyOS that supports slotted programming will be available online soon.

Slotted Programming For Everything?

- External asynchronous events
- Fast sampling
- Multitasking required?

Fast sensor sampling

